



**WIAND ELECTRIC**

# بازرگانی ویند الکتریک

پیشرو در تأمین تجهیزات تابلو برق



# INSULATOR

تنوع بالا + کیفیت عالی + قیمت مناسب = برند برتر

TEL : +98 21 33909393  
33909797

FAX : +98 21 33902121

EMAIL : SALE@WIANDCO.COM

[WWW.WIANDCO.COM](http://WWW.WIANDCO.COM)



# ABOUT WIAND ELECTRIC

WIAND ELECTRIC CO Ltd. was incorporated in the year 2005 with the objective of providing quality components for Electrical Control Panels, Distribution Boards and Bus Ducts. The company is operating in IRAN and International Markets and producing wide range of control panel and distribution board components like Stand Off Insulators and Busbar Supports in DMC, SMC and, Brass Terminal Bars and Fans and switch board accessories such as 8PT ,S8,blockset and MNS series and MV Switchgear accessories for Simoprime .Next ,Pix, Unigear series like Bushing , Contacts ,Sockets, Insulation tube,...

From the time of its inception, the company has grown its designing, engineering, tooling, manufacturing and testing capabilities to become the market leaders in the field. At WIAND ELECTRIC we are striving to understand changing customer needs and enrich the quality of their products by simply making the technology readily usable for them. We are proud to have trained professionals, who study, design, develop, enhance, customize and use of various aspects of products manufactured by us. The quality and design has always been the most emphasized area at WIAND ELECTRIC manufacturing facilities. A free technical consultancy service is available for Short Circuit Testing for designing of Power Control Centers with WIAND ELECTRIC products. WIAND ELECTRIC is committed for excellence in quality and our design department provides different application data to customers for IRI testing. There is an on-going philosophy of research and development in providing advance solutions to customer requirement



# SM SERIES



SM 25- 6 - □

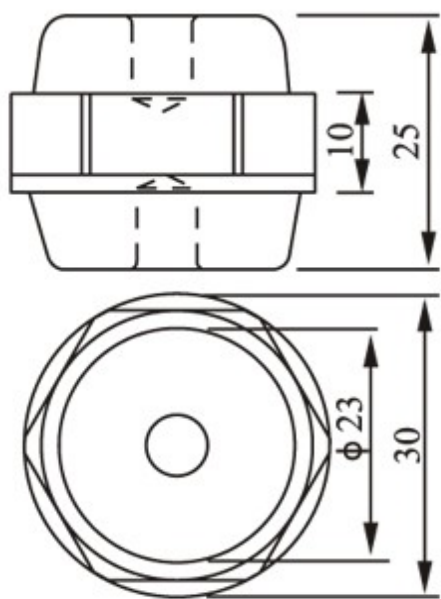
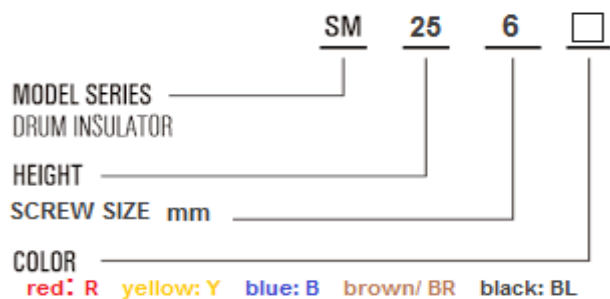

## SM-25

Tensile strength(LBS)	500
Voltage withstand(KV)	6
Torgue strength(FTLBS)	6
screw(mm)	6
screw depth(mm)	9

# SM SERIES



## SM 30-6-□

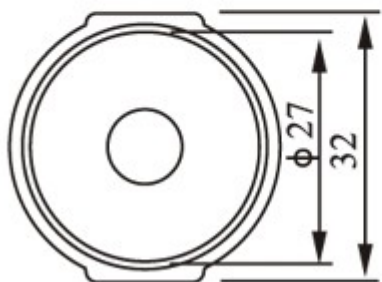
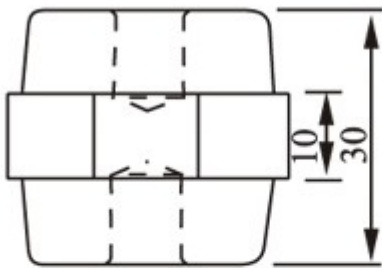
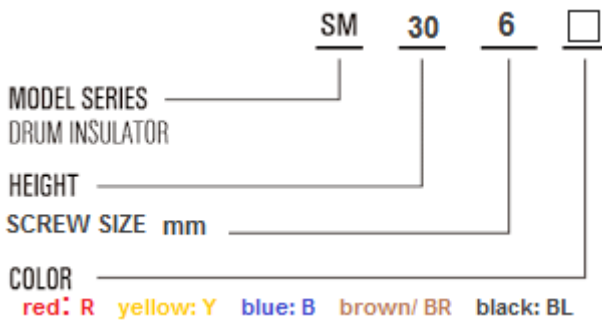

### SM-30

Tensile strength(LBS)	550
Voltage withstand(KV)	8
Torque strength(FTLBS)	8
screw(mm)	8
screw depth(mm)	11

# SM SERIES



SM 35-6-□

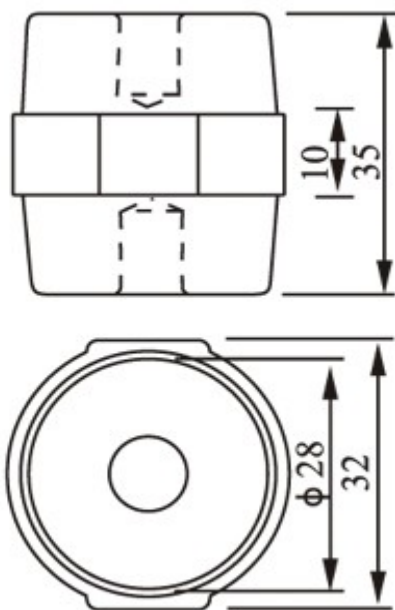
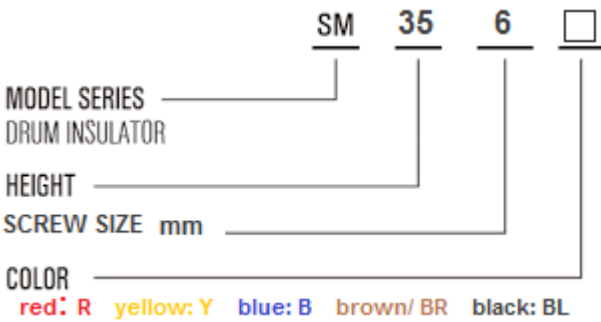

## SM-35

Tensile strength(LBS)	600
Voltage withstand(KV)	10
Torgue strength(FTLBS)	10
screw(mm)	8
screw depth(mm)	11

# SM SERIES



SM 40-8-□

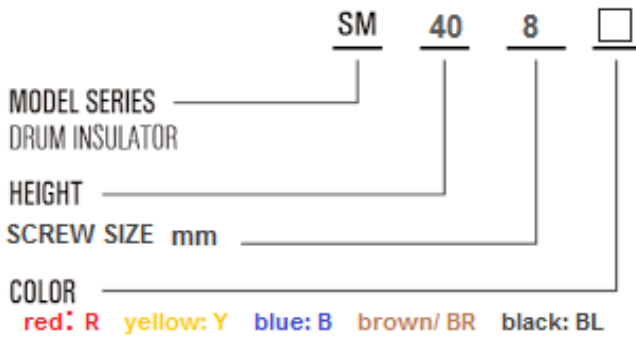

**SM-40**

Tensile strength(LBS)	650
Voltage withstand(KV)	12
Torgue strength(FTLBS)	12
screw(mm)	8
screw depth(mm)	11

# SM SERIES



SM 45-8-□

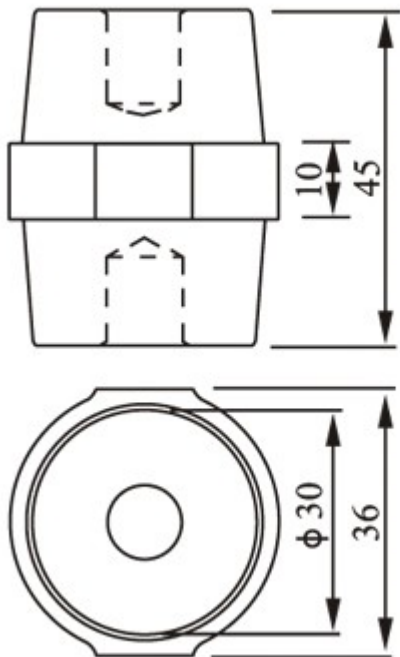
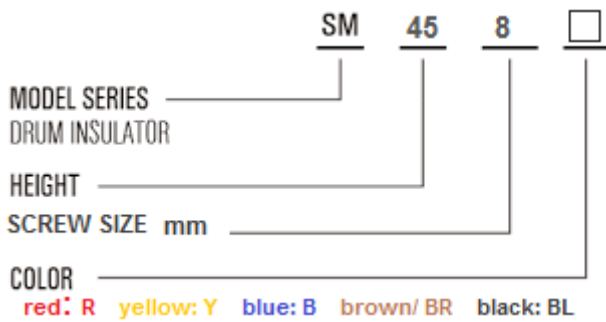

## SM-45

Tensile strength(LBS)	1000
Voltage withstand(KV)	14
Torgue strength(FTLBS)	20
screw(mm)	8
screw depth(mm)	11

# SM SERIES



SM 50-10-□

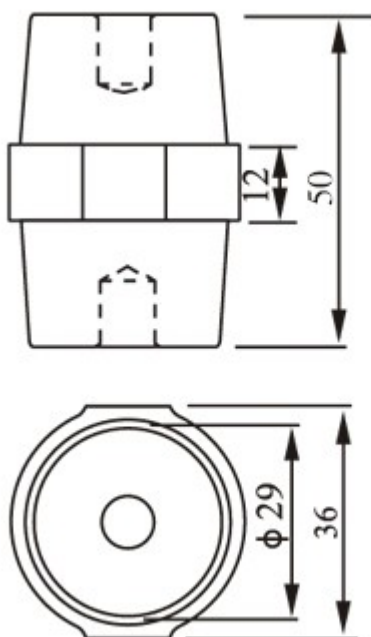
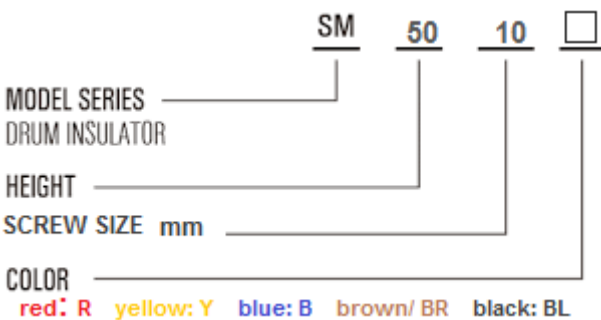

## SM-50

Tensile strength(LBS)	1000
Voltage withstand(KV)	15
Torgue strength(FTLBS)	20
screw(mm)	8
screw depth(mm)	14



# SM SERIES



SM 60-10-□

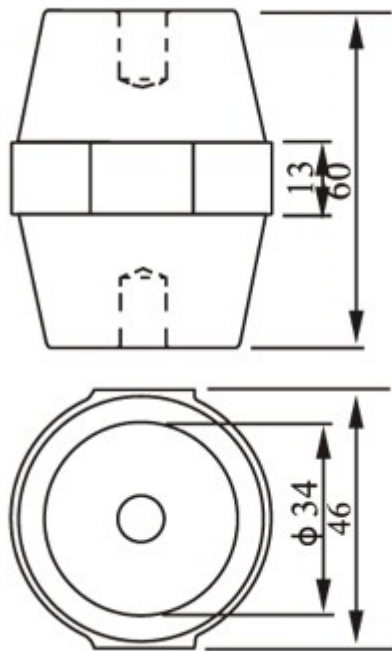
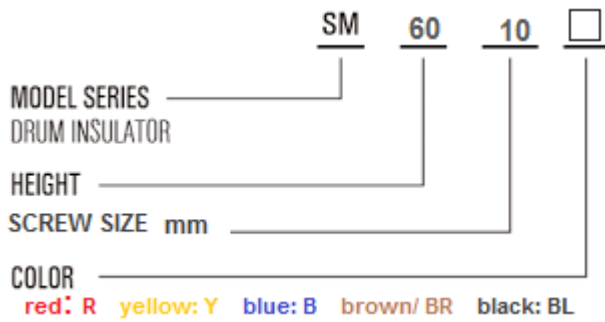

## SM-60

Tensile strength(LBS)	1200
Voltage withstand(KV)	20
Torgue strength(FTLBS)	35
screw(mm)	10
screw depth(mm)	15

# SE4 SERIES



Step insulators

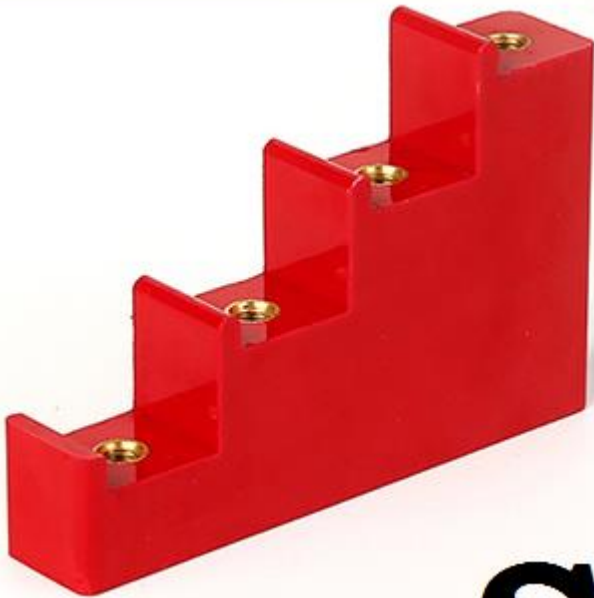

**SE** SERIES



# SE4 SERIES



SE4-20

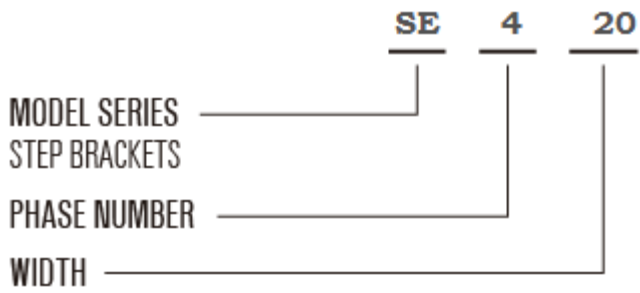

 SE4-20

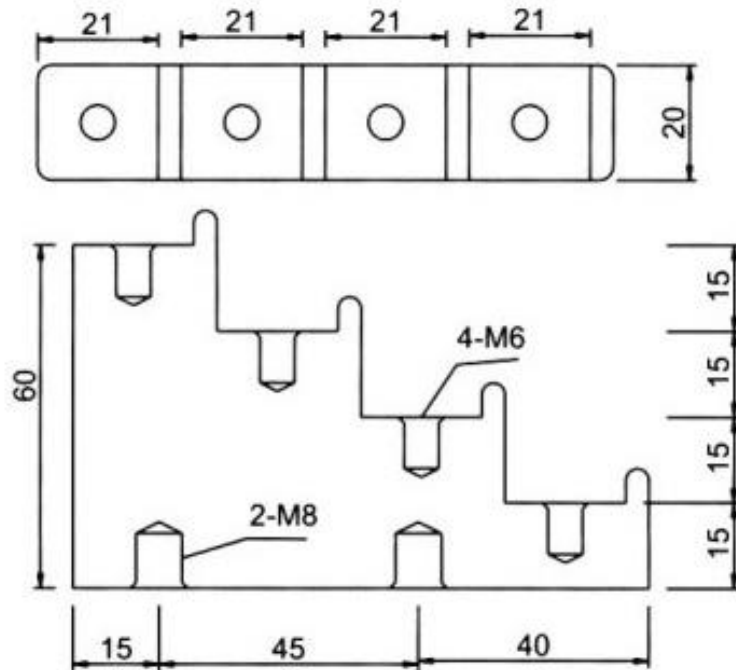

# SE4 SERIES

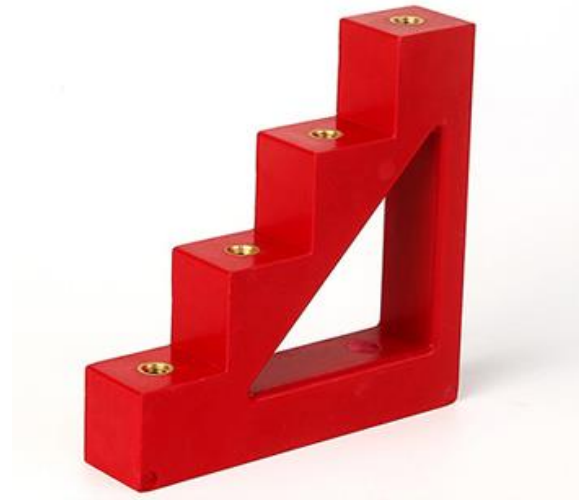

SE4-30

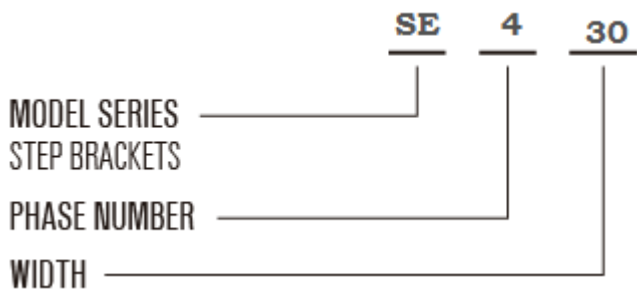

 **CT4-30**

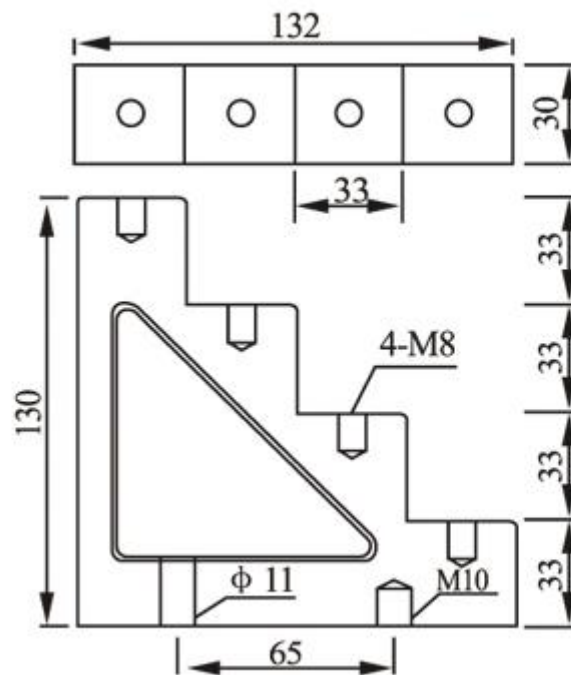

# SE4 SERIES



SE4-40

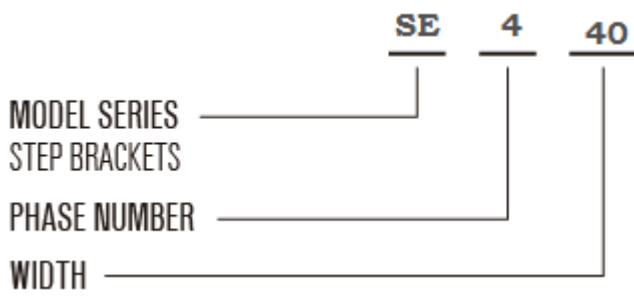

## CT4-40

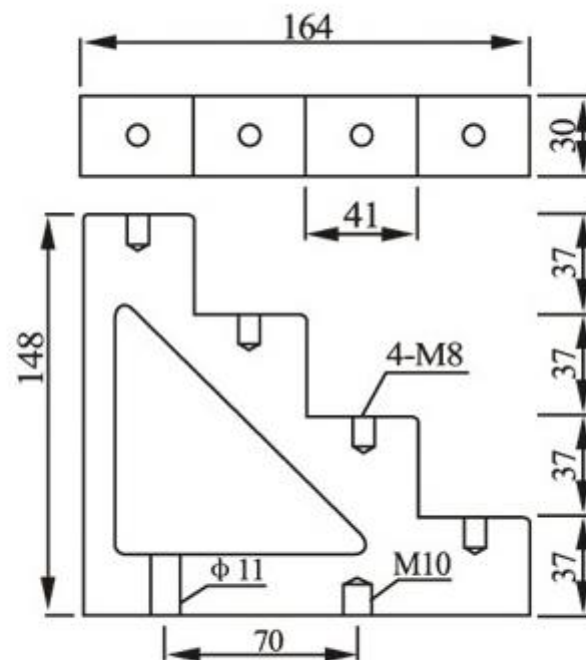

**GB SERIES**



Accordion insulators



**wiand electric**

# GB SERIES



GB -35-6-□

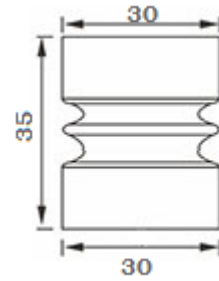
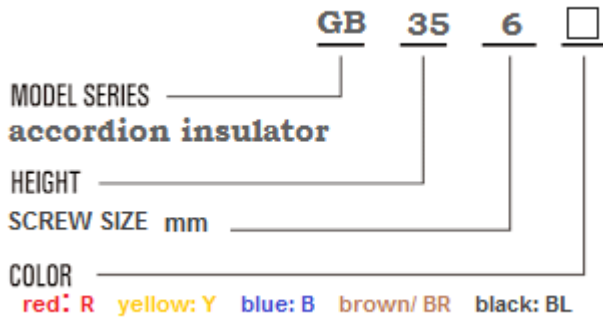

GB -45-8-□

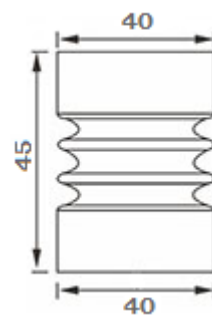
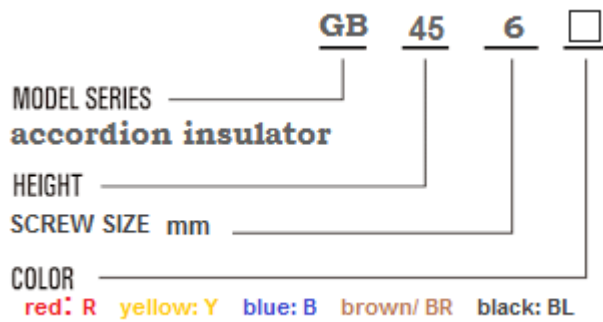

# GB SERIES



GB -55-8-□

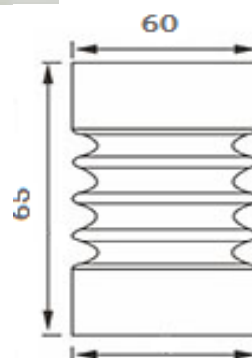
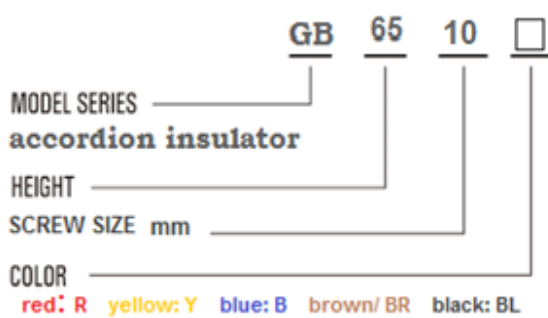
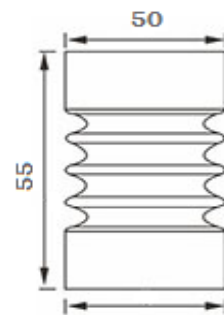
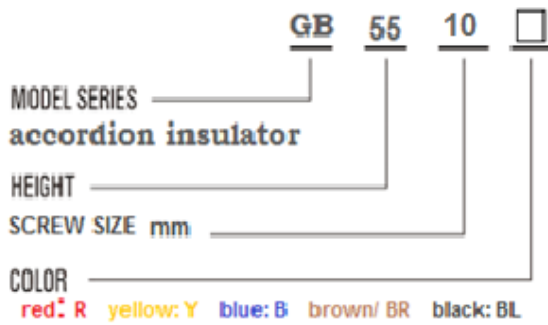



**GU SERIES**

VERTICAL INSULATOR

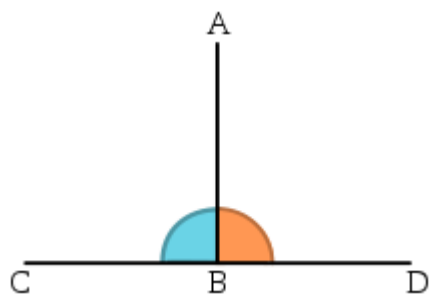

# GU SERIES



GU -100- □

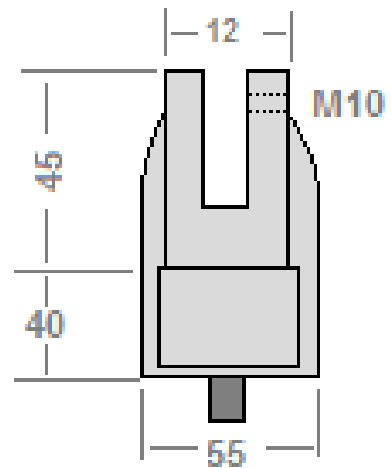
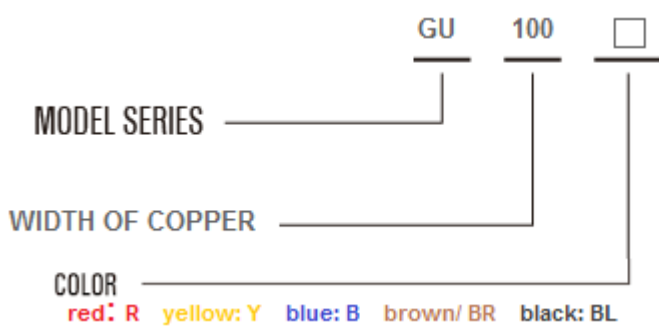

تنوع بالا + کیفیت عالی + قیمت مناسب = برند برتر

TEL : +98 21 33909393  
33909797

FAX : +98 21 33902121

EMAIL : SALE@WIANDCO.COM

WWW.WIANDCO.COM

